

## DATA SHEET - TOOL BOX

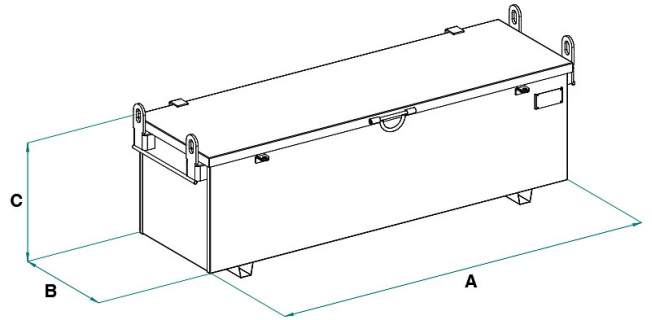

Code	Capacity (kg)	Capacity (L)	Weight (kg)	Dimensions (mm)		
				A	B	C
PA-10.05	400	200	45	900	400	500
PA-10.10	500	420	75	900	900	500
PA-18.06	500	425	80	1700	500	500
PA-20.07	500	1460	165	1950	996	752
PA-17.08E	400	700	80	1700	830	595/415

## DATA SHEET - TOOL BOX

---

Crane accessories



## Tool box

### Assortment of painted tool boxes

We introduce our painted toolboxes, a robust and durable solution for the safe transportation and storage of tools in various work environments. These boxes are carefully designed to offer a combination of strength, corrosion protection, and ease of use. **Main Features:** **Strength and Durability:** The boxes are constructed with high-quality materials to ensure strength and durability, withstanding daily wear and the demands of construction site work. **Protective Coating:** The powder coating adds a protective layer, helping to preserve the aesthetic appearance of the box and shielding it from the elements. **Side Handles and Lifting Brackets:** Side handles allow for easy manual movement, lifting brackets at the base facilitate transport with forklifts, and side hooks enable lifting with four-leg chains and cranes. **Protection:** The construction of the boxes ensures that tools inside are protected from adverse weather conditions. **Lockable:** Option to secure with a padlock to ensure the safety of tools during transport and storage. Upon request, we can customize the dimensions of the boxes to meet the specific needs of our customers, guaranteeing a tailored solution for every work situation. This product is constructed and tested according to UNI EN ISO 12100, UNI EN 10027-1, and UNI EN 10204 standards and comes with the appropriate metal label and conformity certificate. All our products are covered by a one-year warranty (European Directive).

### Application sectors

 Construction