

DATA SHEET - RECTANGULAR CRANE MAN BASKET

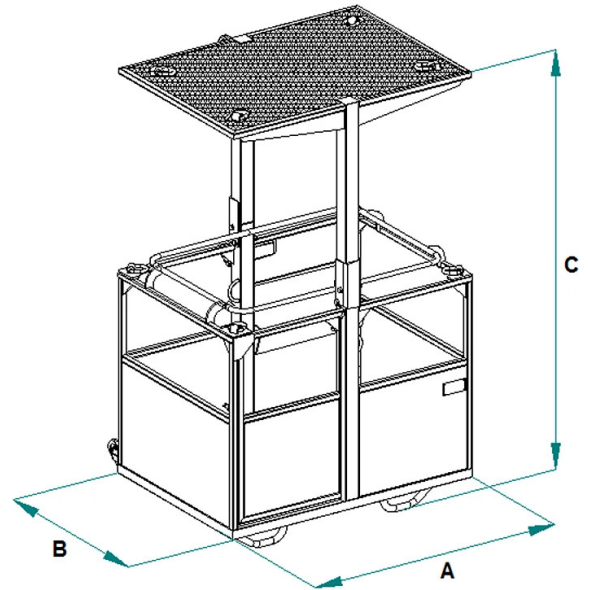

Code	Capacity (kg)	Weight (kg)	Dimensions (mm)		
			A	B	C
CPP-G1C	200	190	700	700	2323
CPP-G2C	300	290	1400	1000	2323
CPP-G3C	450	445	2000	1000	2323
CPP-G4C	600	540	2250	1205	2323

DATA SHEET - RECTANGULAR CRANE MAN BASKET

Crane man baskets



Rectangular crane man basket

Rectangular man-lifting basket with removable roof

The series of rectangular crane baskets represents a reliable solution for lifting two, three, or four people during routine or extraordinary maintenance operations, as well as for moving between floors or different locations on the construction site. On-board safety is ensured by construction features such as an inward-opening door equipped with a spring for automatic closure and a suitable locking system, a safety handrail to prevent accidental finger crushes, and anchoring points for connecting a fall restraint device. The internal tool compartment helps keep the basket clear of ground clutter, reducing the risk of imbalance for the operators. Lifting is carried out on 4 points located on the sides of the roof through chains connected to welded eye bolts with junction links that ensure stability and safety according to current regulations. The basket walls are equipped with swiveling wheels, ensuring lifting along building facades without causing damage or scratches. This series of baskets also features a easily removable roof for greater flexibility of use in different situations.

Application sectors

 Lifting