

DATA SHEET - HEAVY DUTY CONICAL CONCRETE BUCKET WITH RUBBER HOSE

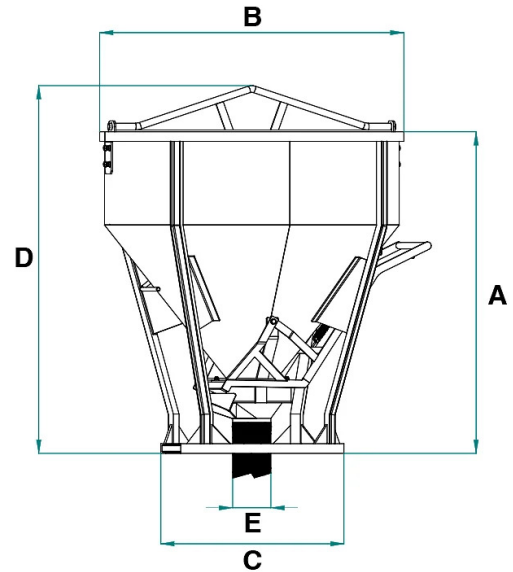

Code	Capacity (kg)	Capacity (L)	Weight (kg)	Dimensions (mm)				
				A	B	C	D	E
CT-50N	1300	500	145	1230	1050	885	1405	200
CT-80N	2080	800	220	1491	1250	925	1665	200
CT-99N	2600	1000	270	1415	1590	965	1622	200
CT-150N	3900	1500	330	1680	1590	965	1888	200
CT-200N	5200	2000	410	1705	1850	1225	1915	200
CT-250N	6500	2500	435	1905	1885	1225	2008	200
CT-300N	7800	3000	625	2100	1885	1225	2380	200

DATA SHEET - HEAVY DUTY CONICAL CONCRETE BUCKET WITH RUBBER HOSE

Concrete buckets



Heavy duty conical concrete bucket with rubber hose

Heavy duty concrete bucket with central discharge and rubber hose

We are pleased to present the CT-N conical concrete bucket model, a reinforced version of our reliable CT model, designed to offer superior performance and greater durability in daily pouring operations on construction sites. The CT-N model features a central discharge with a flexible rubber hose and a lever-operated opening system with rope and automatic spring closure. The bucket comes with a 2-meter long rubber hose with a diameter of 200 mm. Different lengths and diameters are available upon request. The bucket features a guillotine closure valve and a special deflector to prevent the accidental spillage of concrete during pouring. The lowered edge height also facilitates filling with a concrete mixer truck, reducing downtime and increasing safety on the site. This design allows for precise control of the pour and even distribution of concrete, making it particularly suitable for use on formwork and columns. CT-N buckets with a capacity of 2500 L and above are equipped with 4 lifting points instead of a lifting arm, to ensure greater safety and stability during lifting operations. The CT-N model is available in various sizes and capacities, as indicated in the table below, and can be customized to meet your specific project needs. All our buckets are built and tested in accordance with the stringent UNI EN ISO 12100, UNI EN 13854, ISO 8686, UNI EN 10027, and UNI EN 10204 standards. Each product is accompanied by a metal ID plate, a certificate of conformity, and a user and maintenance manual to ensure proper use over time. Additionally, all our products are covered by a one-year warranty, in compliance with the European Directive and are built with certified materials to ensure durability and safety, meeting the quality standards required in the construction field.

Application sectors

 Construction