

DATA SHEET - ALUMINUM TOOL BOX

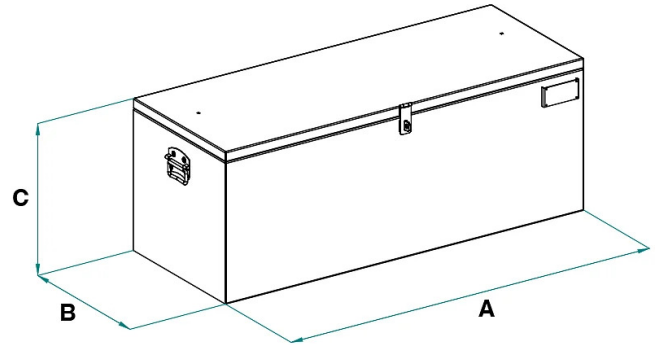

Code	Capacity (L)	Weight (kg)	Technical data notes	Dimensions (mm)		
				A	B	C
PA-650-1	117	14	1 handle	650	450	400
PA-750-1	135	16	1 handle	750	450	400
PA-800-1	200	19	1 handle	800	500	500
PA-850-1	153	17	1 handle	850	450	400
PA-900-1	225	21	1 handle	900	500	500
PA-1000-1	250	23	1 handle	1000	500	500
PA-1100-1	275	24	1 handle	1100	500	500
PA-1200-1	300	26	1 handle	1200	500	500
PA-1300-1	325	28	1 handle	1300	500	500
PA-1000-1P	250	27	1 handle + support skids	1000	500	500+65
PA-1300-1P	325	32	1 handle + support skids	1300	500	500+65
PA-1250-2	375	33	2 handles	1250	600	500
PA-1900-2	665	46	2 handles	1900	700	500
PA-100S-2P	500	42	2 handles + support skids	1000	1000	500+65
PA-1250-2P	375	37	2 handles + support skids	1250	600	500+65



DATA SHEET - ALUMINUM TOOL BOX

Code	Capacity (L)	Weight (kg)	Technical data notes	Dimensions (mm)		
				A	B	C
PA-1650-2P	697	49	2 handles + support skids	1650	650	650+65
PA-1900-2P	665	51	2 handles + support skids	1900	700	500+65



DATA SHEET - ALUMINUM TOOL BOX

Crane accessories



Aluminum tool box

Assortment of aluminum tool boxes

We introduce our aluminum toolboxes, the ideal solution for the safe transportation and efficient organization of tools on construction sites, in warehouses, and other work environments. These boxes are carefully designed to offer durability, practicality, and versatility. **Main Features:** **Strength and Lightness:** Made from high-quality aluminum, the boxes offer an optimal combination of strength and lightness, ensuring long-lasting durability without adding significant weight. **Organized Internal Compartments:** Designed with internal compartments of various sizes, the boxes facilitate tool organization and help keep everything in order, optimizing work time. **Side Handles and Lifting Brackets:** Equipped with side handles for manual transport and lifting brackets to facilitate operations with cranes or forklifts. **Waterproof:** The sealed construction of the boxes ensures that tools inside are protected from adverse weather conditions. **Rust Resistance:** The aluminum used makes the boxes rustproof, preserving their integrity over time. **Lockable:** Option to secure with a padlock to ensure the safety of tools during transport and storage. **Optional Wheels:** Upon request, the boxes can be fitted with wheels, further increasing their versatility. Discover the practicality and reliability of our aluminum toolboxes, designed to meet the needs of every professional. This product is constructed and tested according to UNI EN ISO 12100, UNI EN 10027, and UNI EN 10204 standards and comes with the appropriate metal label and conformity certificate. All our products are covered by a one-year warranty (European Directive).

Application sectors

 Construction