

DATA SHEET - CLOSED DRUM STORAGE CABINET

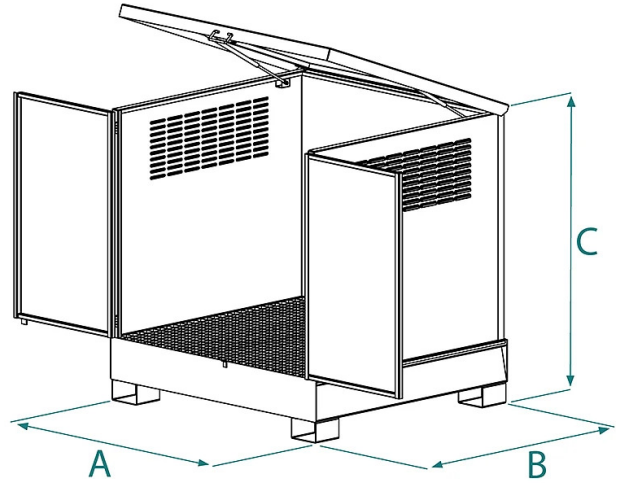

Code	Capacity (L)	Weight (kg)	No. of 200L drums	Dimensions (mm)		
				A	B	C
PFL-1	210	210	1			
PFL-2	230	225	2	850	1340	1450
PFL-4	280	270	4	1250	1340	1420

DATA SHEET - CLOSED DRUM STORAGE CABINET

Crane accessories



Closed drum storage cabinet

Storage cabinet for 200 L drums

Introducing our drum storage cabinet, a safe and efficient solution for the management and storage of drums on construction sites as well as in industrial and commercial environments. This cabinet is designed with a sturdy structure and resilient materials, ensuring reliable protection for your drums. Key Features:

- **Storage Capacity:** The cabinet is designed to accommodate drums of various sizes, offering flexible storage capacity to meet your specific needs.
- **Robust Structure:** Built with high-quality materials, the cabinet ensures a sturdy and durable structure, ensuring longevity and content protection.
- **Security:** Equipped with secure closures, the cabinet ensures that drums are safe from unauthorized access or unwanted situations.
- **Adequate Ventilation:** The cabinet's design includes adequate ventilation systems to ensure a safe and controlled internal environment.
- **Ease of Access:** Wide-opening doors and convenient locking systems allow easy access to the cabinet's contents for loading and unloading operations.
- **Regulatory Compliance:** The cabinet is designed and built in accordance with safety regulations and industry standards to ensure regulatory compliance. We have available 3 different models, to accommodate 1, 2, or 4 drums in a vertical position. Container handling can be done with a forklift or a 4-arm chain. The containers, in which the drums are placed, are constructed with galvanized grating and a collection tray that provides an additional level of safety, facilitating the management of any leaks or spills. Upon request, we also offer a tubular drum rack designed to accommodate 2 drums in a horizontal position, only for the 4-drum model (PFL-4). This product is built and tested according to UNI EN ISO 12100, UNI EN 10027-1, and UNI EN 10204 standards and is issued with the appropriate metal ID plate and certificate of conformity. All our products are covered by a one-year warranty (European Directive).

Application sectors

 Ecology