

## DATA SHEET - GAS BOTTLE CAGE

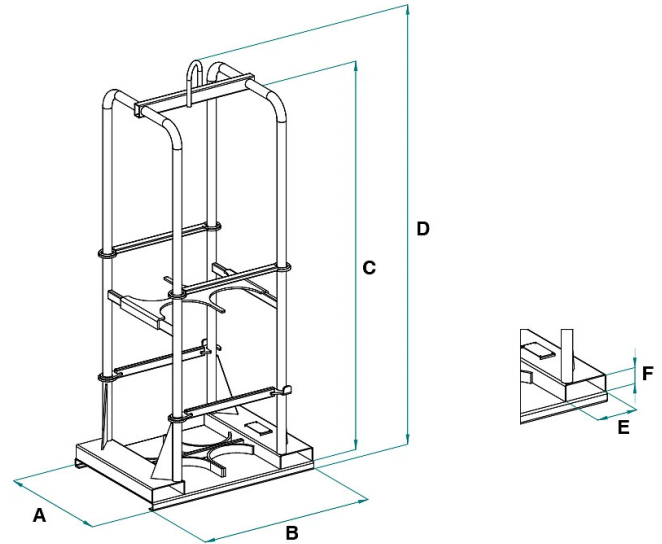

Code	Capacity (kg)	Weight (kg)	Diametre (mm)	Dimensions (mm)					
				A	B	C	D	E	F
PB-1	75	55	250	366	626	1782	2037	170	63
PB-2	150	80	250	633	626	1750	2000	170	63
PB-4	300	95	250	633	876	1750	2000	170	63
PB-6	450	115	250	633	1146	1760	2020	170	63

## DATA SHEET - GAS BOTTLE CAGE

---

Crane accessories



## Gas bottle cage

### Container for 1, 2, 4, and 6 technical gas cylinders

We present our comprehensive line of gas cylinder storage containers, a versatile solution for the safe storage and transport of technical gas cylinders. Available in various capacities, including options for 1, 2, 4, and 6 cylinders, these containers are designed to meet the specific needs of cylinder management in industrial settings. Key Features: Capacity Versatility: Our range offers various options, allowing you to select the most suitable model for your specific storage needs, with capacities from 1 to 6 cylinders and different cylinder diameter sizes. Robust Structure: The containers are built with a sturdy structure to ensure durability and strength in daily use, providing a reliable and safe solution. The container can be lifted using a chain through the hook welded at the top or can be easily moved with a forklift by inserting the forks at the base. This product is constructed and tested according to UNI EN ISO 12100, UNI EN 10027-1, and UNI EN 10204 standards and comes with the appropriate metal ID plate and conformity certificate. All our products are covered by a one-year warranty (European Directive).

### Application sectors

 Ecology