

DATA SHEET - LAYDOWN CONCRETE COLUMN SKIP WITH RUBBER HOSE AND FORKLIFT POCKETS

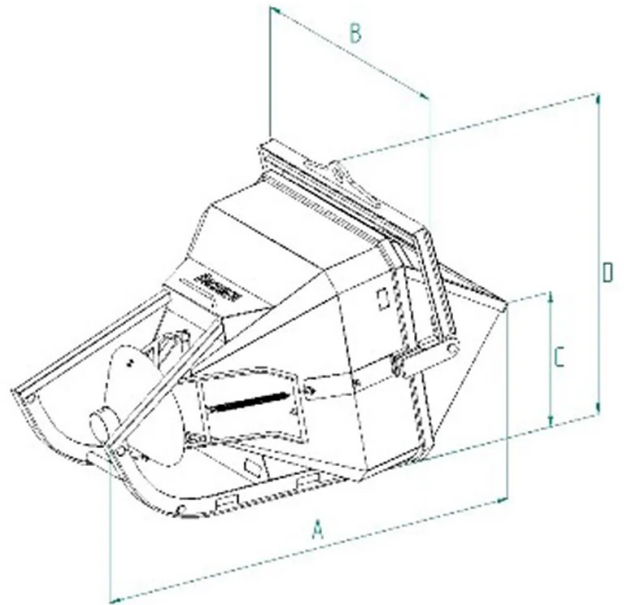

Code	Capacity (kg)	Capacity (L)	Weight (kg)
BC-40	1040	400	300
BC-50	1300	500	315
BC-60	1560	600	325
BC-80	2080	800	380
BC-99	2600	1000	455
BC-125	3250	1250	495
BC-150	3900	1500	650
BC-200	5200	2000	745
BC-250	6500	2500	990
BC-300	7800	3000	1410

DATA SHEET - LAYDOWN CONCRETE COLUMN SKIP WITH RUBBER HOSE AND FORKLIFT POCKETS**Concrete buckets****Laydown concrete column skip with rubber hose and forklift pockets****Laydown concrete bucket with rubber hose and forkliftable base**

The concrete bucket, with lever-operated opening and rubber hose, is the ideal choice for precise and reliable pours on the most demanding construction sites and for intensive use. Its design, tailored to the needs of the most challenging sites, makes it indispensable for pouring large quantities of concrete with extreme precision into formwork, pillars, or slabs, thereby avoiding potential structural issues from casting errors. The bucket is equipped with a guillotine valve operated by a lever. A spring allows for automatic closure of the discharge, while a rope allows the bucket to be opened even at height. The bucket features a forklift-compatible base welded to the bottom, facilitating movement with forklifts or telescopic handlers for easier handling on-site during loading and unloading from trucks. The two-meter-long rubber hose, with a diameter of 200 mm, ensures a controlled and precise flow of concrete during pouring. A unique feature of these buckets is the horizontal ground loading method, which makes the bucket, even if of large capacity, very low at the edge, allowing the concrete mixer to fill it without any impediment. Once filled, the bucket is safely lifted by the crane through a bale arm, automatically repositioning itself vertically and becoming ready for new use, thus ensuring high efficiency and ease of use on-site. All our buckets are built and tested in accordance with the strict standards UNI EN ISO 12100, UNI EN 13854, ISO 8686, UNI EN 10027, and UNI EN 10204. Each product comes with a metal ID plate, a certificate of conformity, and a user and maintenance manual to ensure proper use over time. Additionally, all our products are covered by a one-year warranty, in compliance with the European Directive.

Application sectors **Construction**