

DATA SHEET - CRANE LIFTING BIN WITH 4 LEGS CHAIN

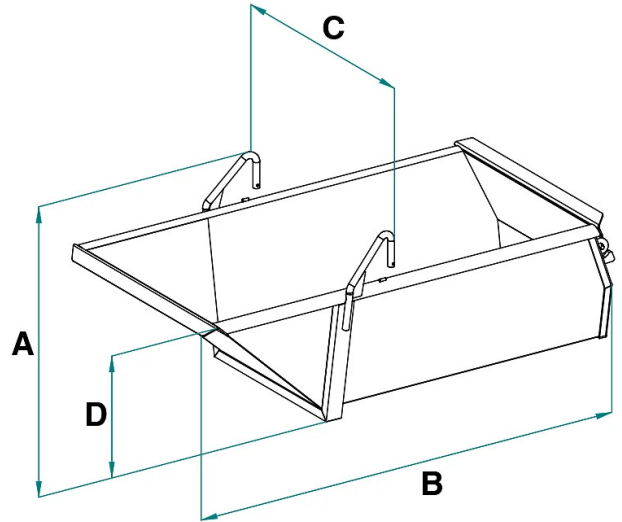

Code	Capacity (kg)	Capacity (L)	Weight (kg)	Dimensions (mm)			
				A	B	C	D
A-50H	500	900	130	822	1937	891	622
A-99H	1000	1800	220	884	2342	1163	685
A-150H	1500	2700	345	1030	2582	1358	828

DATA SHEET - CRANE LIFTING BIN WITH 4 LEGS CHAIN

Boat skips



Crane lifting bin with 4 legs chain

Boat skip for crane complete with 4-arm chain

This boat skip equipped with a 4-leg chain is the ideal choice for the safe handling of a wide range of materials on construction sites. This robust equipment is designed to ensure reliable performance and maximum safety during lifting and transport operations. This model features low and uniformly high walls, which greatly simplifies the loading and unloading of materials of different sizes, ensuring safe and stable lifting. Key Features:

- **4-Leg Chain:** The 4-leg chain provides uniform load distribution over the entire surface of the bucket, ensuring stable and safe lifting of various materials. This feature helps minimize the risk of accidents on the job site.
- **Versatility:** This bucket is suitable for handling a wide range of materials, including aggregates, debris, sand, gravel, and more. Its versatility makes it ideal for multiple applications on construction sites.
- **Tipping System:** The bucket tips easily and efficiently thanks to the two welded chain pendants positioned at the back of the bucket. This system allows for precise and controlled material discharge.
- **Robustness and Durability:** Built with high-quality materials and subjected to stringent quality controls, this bucket is designed to withstand the toughest site conditions. Its robustness and durability minimize the need for maintenance.
- **Regulatory Compliance:** The bucket complies with all applicable safety standards and regulations. Each unit is supplied complete with documentation, including certificates of conformity and user and maintenance manuals.
- **Standard Warranty:** We offer a standard warranty in accordance with European directives, ensuring our customers' peace of mind.

Application sectors

 Construction